

Users Manual

**R2GC 200, R2GC 250, R2GC 300, R2GC 400
STORAGE WATER HEATERS**



Date of manufacture:

Serial number:

Checked by:



EN
v. 1.1



CONTENTS

1 Description	3
1.1 Model line	3
1.2 Tank protection	3
1.3 Thermal insulation	3
1.4 Connection points	3
1.5 Packing	3
2 General Information	3
3 Technical Data and Dimensions of R2GC Tanks	4
4 Operation	5
5 Examples of Assigning Connection Points	5
6 Installation and Commissioning	7
6.1 Connection to heat sources	7
6.2 Connection to a solar system	7
6.3 Heating rod installation	7
6.4 Connection to water mains	7
6.5 Electronic anode installation	7
6.6 Commissioning	8
7 Maintenance, Replacement of Magnesium Anode Bar	8
8 Disposal	8
9 Warranty	8

1 - Description

R2GC storage water heater ("tank" further on) is designed to accumulate heat for domestic hot water (DHW). The tank is heated from hot-water heat exchangers installed inside (2 heating coils). The lower heating coil can be used to connect e.g. a solar system while the upper heating coil can be fed from e.g. a gas-fired boiler or an accumulation tank. The speed of heating up the tank to the desired temperature depends primarily on the fluid temperature entering the heat exchanger. Higher temperatures of the incoming fluid mean quicker heating up the tank, and vice versa. Should the output of the heat exchanger be insufficient for some applications, an electric heating rod can be installed into the tank.

The entire hydraulics of a heating system shall be designed properly in order to achieve flawless operation of the tank, i.e. the position of circulation pumps for heat sources and heating circuits, valves, check valves etc.

1.1 - Model line

These storage water heaters are supplied in four sizes: 200, 250, 300 and 400 l.

1.2 - Tank protection

The tank body is made of sheet steel, finished outside with durable ecologic powder coating. Its inner enamel lining works as anticorrosion protection and together with a magnesium anode rod it guarantees a long service life. The magnesium anode rod shall be inspected regularly - see point 7. Maintenance, Replacement of Magnesium Anode Rod. An electronic anode can be also used; its lifetime covers the lifetime of the tank if its operation indicator works right.

1.3 - Thermal insulation

Tanks are insulated with ecologic 55mm PUR foam (50mm for R2GC 400) that reduces thermal loss to minimum.

1.4 - Connection points

- 4× lateral, G 1" female thread, for heating coils
- 2× lateral, G 1" female thread, cold water in, hot water out
- 2× lateral, G 1/2" female thread, for temperature probes
- 1× lateral, G 3/4" female thread, for recirculation
- 1× upper, G 5/4", for magnesium anode rod
- 1× lateral, G 6/4" female thread, for electric heating rod
- 1× lateral, G 1/2" female thread, for thermometer

1.5 - Packing

Tanks are delivered standing, each screwed to its pallet, shrink-wrapped. It is forbidden to transport and/or store the storage tanks in a horizontal position.

2 - General Info

The appliance shall be installed by a qualified person according to valid rules.

This Users Manual is an integral and important part of the product and must be handed over to the User. Read carefully the instructions in this Manual as they contain important information concerning safety, installation, operation and maintenance. Keep this Manual for later reference.

Using the storage water heater for other purposes than above described is forbidden and the manufacturer accepts no responsibility for damage caused by improper or wrong use.

3 - Technical Data and Dimensions of R2GC Tanks

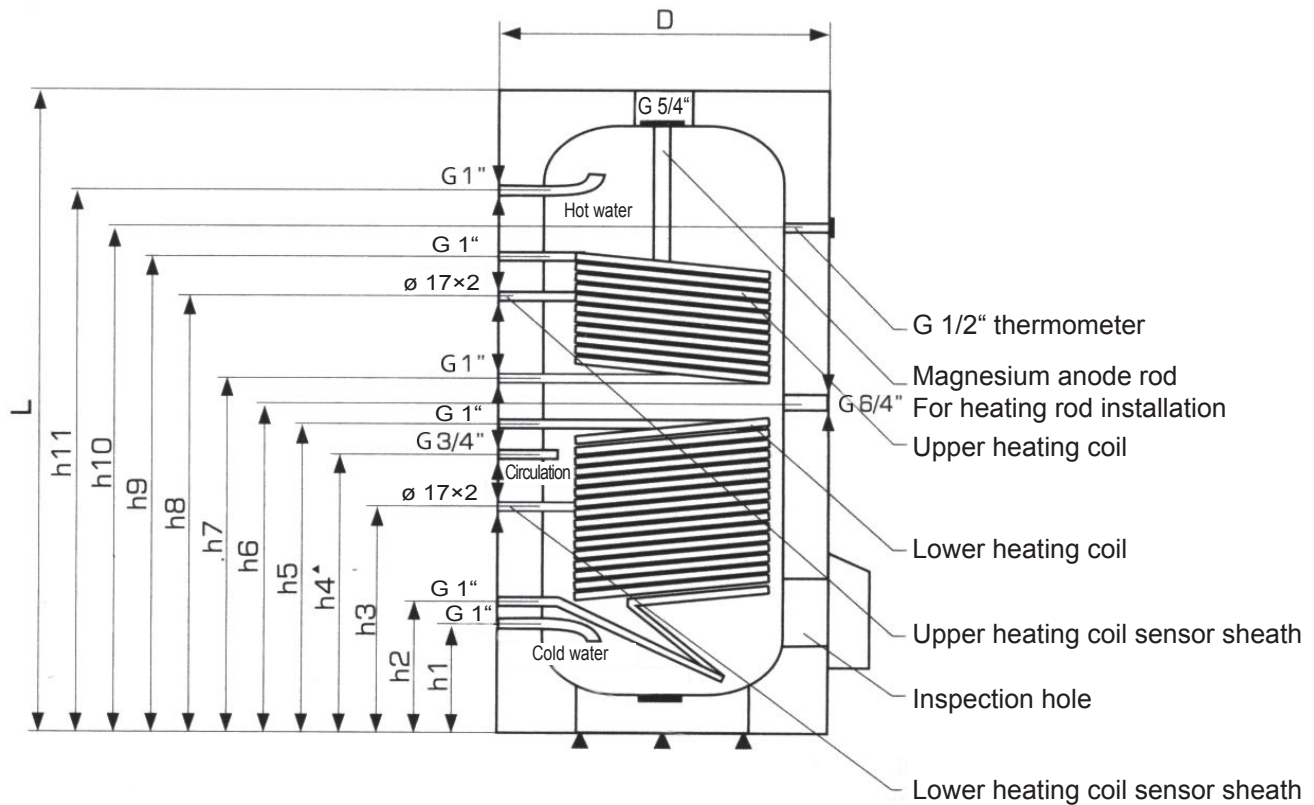

Openings for a heating rod and thermometer are located opposite the other ones.

	Units	R2GC 200	R2GC 250	R2GC 300	R2GC 400
Volume	[l]	200	250	300	400
Cold water inlet max. pressure	[MPa]	0.6	0.6	0.6	0.6
Max. working temperature	[°C]	100	100	100	100
Lower heating coil surface	[m²]	1	1.2	1.4	1.8
Lower heating coil volume	[l]	5.5	6.6	8.6	11.5
DHW heating $\Delta t=35^\circ\text{C}$ (80/60 - 10/45) - lower heating coil	[kW]	34.6	41.5	48.5	62.3
Flow rate	[l/h]	850	1020	1190	1540
Upper heating coil surface	[m²]	0.7	1.0	1.1	1.3
Upper heating coil volume	[l]	4.5	5.5	6.4	7.4
DHW heating $\Delta t=35^\circ\text{C}$ (80/60 - 10/45) - upper heating coil	[kW]	24.2	34.6	38.1	45
Flow rate	[l/h]	600	850	940	1110
Heating water needed	[m³/h]	2.7	2.85	3.0	3.0
h1	[mm]	210	130	210	240
h2	[mm]	290	210	290	320
h3	[mm]	400	355	440	570
h4	[mm]	570	520	580	770
h5	[mm]	500	620	760	870
h6	[mm]	570	680	780	900
h7	[mm]	640	740	845	980
h8	[mm]	710	910	1015	1150
h9	[mm]	820	1080	1090	1330
h10	[mm]	830	1010	1170	1310
h11	[mm]	900	1170	1260	1410
L	[mm]	1140	1300	1450	1660
D	[mm]	660	660	660	700
Weight	[kg]	98	122	133	162

4 - Operation

This tank is designed for operation in pressure circuits. Water can be heated inside in its heat exchangers (heating coils) from several heat sources, e.g. various hot-water boilers, renewable energy sources (heat pumps, solar collectors). An electric heating rod can be installed to backup DHW as well. DHW temperature inside the tank shall be kept between 60 and 65 °C. This temperature guarantees optimum operation and the best protection against Legionella bacteria.

5 - Examples of Assigning Connection Points

Conn. point	Example I. with a gas boiler	Example II. with a boiler and accum. tank
G 5/4" upper flange	magnesium anode	magnesium anode
G 1/2" thermometer	thermometer	thermometer
G 6/4"	plug	electric heating rod
h1	cold water inlet	cold water inlet
h2	outlet into a solar system	outlet into a solar system
h3	temperature probe, thermostat	temperature probe, thermostat
h5	inlet from a solar system	inlet from a solar system
h7	return to a gas boiler	return to an accum. tank
h8	temperature probe, thermostat	temperature probe, thermostat
h4	circulation	circulation
h9	inlet from a gas boiler	inlet from an accum. tank
h11	hot water outlet	hot water outlet

Connections depend on the circuit to be connected, the a.m. examples are informative only.

Example I.

With a gas boiler and solar system.

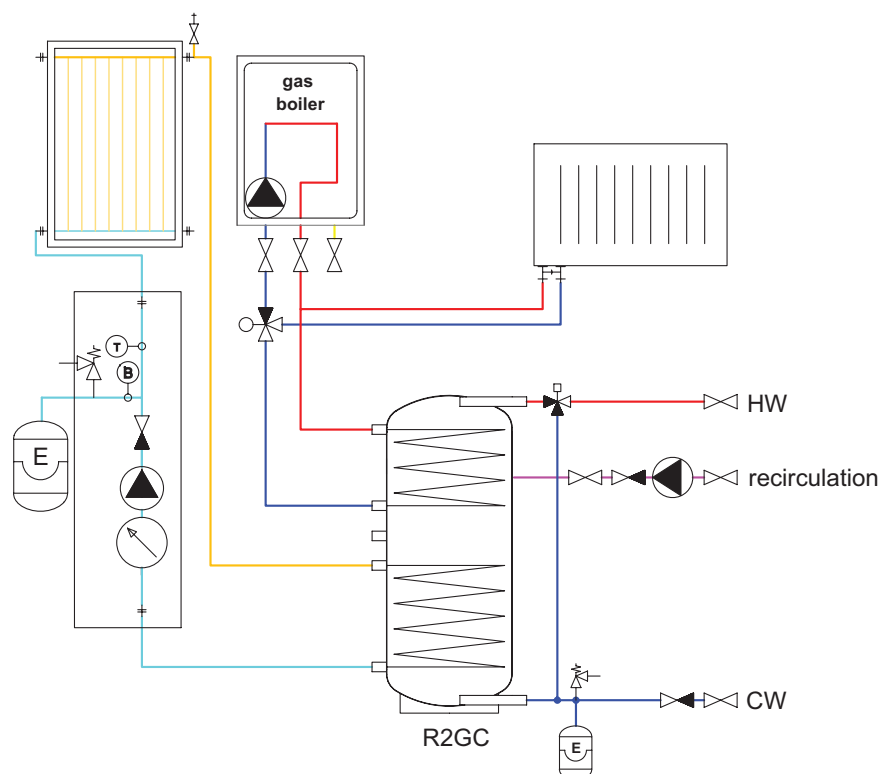

Example II.

With a solid fuel boiler, solar system and accumulation tank.

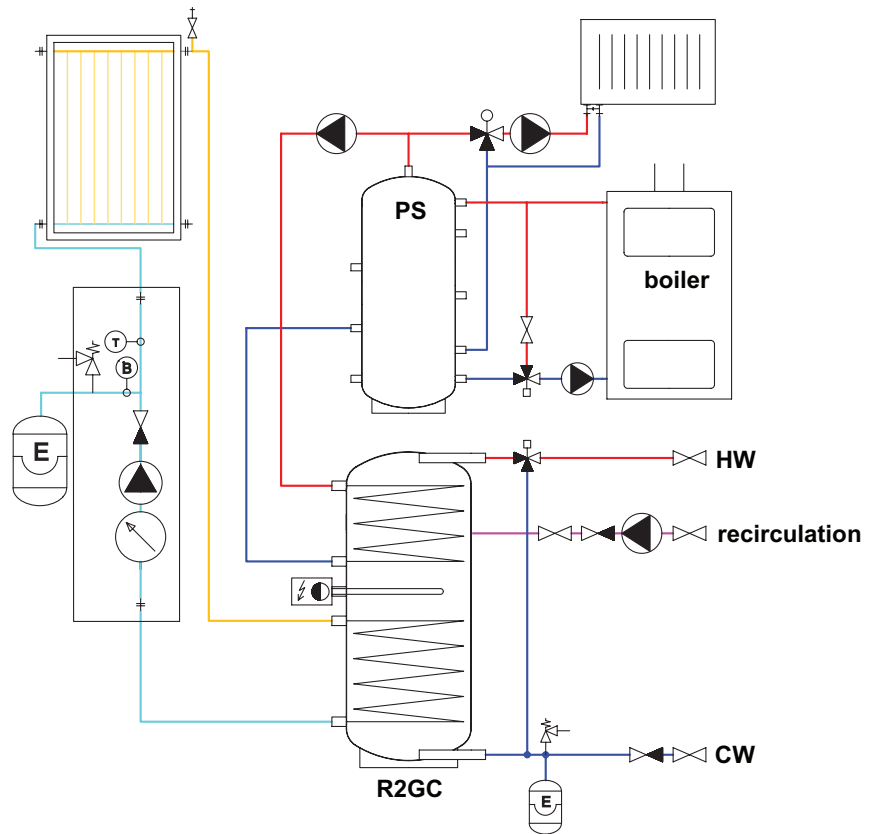

Table of limit values for total dissolved solids in hot water

Description	pH	Total dissolved solids (TDS)	Ca	Chlorides	Mg	Na	Fe
Max. value	6.5 - 9.5	600 mg/l	40 mg/l	100 mg/l	20 mg/l	200 mg/l	0,2 mg/l

6 - Installation and Commissioning

Installation must meet valid rules and may be done only by qualified staff. The tank shall be placed on the floor, as close to the heat source as possible.

Warning: Defects caused by improper installation, use or handling are not covered by warranty.

6.1 - Connection to heat sources

Connect heating circuits to the inlets to and outlets from heating coils. The heat source for the tank - 2 enameled coils - connects with G 1" coupling.

6.2 - Connection to a solar system

The tank can be used with a solar system. In such a case, the inlet for hot heat-carrying liquid coming from the solar system shall be connected to the G 1" upper sleeve of the lower heating coil and the lower outlet to the return piping to the solar system. Insulate all the piping between the tank and the solar system.

6.3 - Heating rod installation

The G 6/4" side sleeve is designed to accommodate an electric heating rod. Heating rods of output up to 6 kW can be used (depending on the tank diameter and rod length), connected either directly to the mains (thermostat-equipped rods), or to a heating system controller. The installation may be done by qualified staff only.

Warning: Electric heating elements shall be protected by a safety thermostat.

6.4 - Connection to water mains

DHW piping shall be done according to valid rules. G 1" threaded couplers are used to connect the tank to a cold water inlet and hot water outlet. A 6bar safety valve shall be installed at the cold water inlet, installation of a reducing valve is recommended. If the pressure from water mains exceeds 6 bar, a reducing valve is necessary. In order to prevent water loss, an expansion tank should be installed at the cold water inlet as well (8l volume for R2GC 200, 250 and 12l volume for R2GC 300 and 400).

Should the water be too hard, install a water softener before the tank. In case the water contains mechanical impurities, install a strainer.

A suitable thermostatic mixing valve should be installed at the hot-water outlet from the tank, preventing too hot water from entering the taps.

Install a drain valve to the lowest point of the tank.

Complete DHW piping shall be properly insulated.

6.5 - Electronic anode rod installation

So called electronic anode can be used instead of the magnesium one. Its principle advantage is that its proper function is signaled by a control lamp while a magnesium anode rod needs to be taken out for check. In such a case, just visual check of the electronic anode is sufficient.

Please use a G 5/4" to G 1/2" reducing coupler when installing an electronic anode. In order to protect the tank properly and meet its warranty conditions, select an anode from the table below. A space of about 0.5m is needed between the tank top and ceiling to install/exchange the electronic anode rod (0.35m for R2GC200).

Kit for R2GC storage water heaters

Code	Anode rod length [mm]	For storage water heaters
9176	350 (200/150)	R2GC 200
9177	500 (350/150)	R2GC 250, R2GC 300, R2GC 400

6.6 - Commissioning

Fill the heating circuits with the appropriate fluids and air-bleed the entire system. Check all connections for leaks and verify the system pressure.

The quality of top-up and heating water is set by ČSN 07 7401:1992. **Hot water quality must meet the conditions shown in the Table of limit values for total dissolved solids in hot water, page 6 of this Manual.**

Fill the heating circuits with the appropriate fluids and air-bleed the entire system. Check all connections for leaks and verify the system pressure. Set the heating controller in compliance with the documentation and manufacturer's recommendations. Check regularly a proper function of all control and adjusting elements.

7 - Maintenance, Replacement of Magnesium Anode Rod

If the tank is fitted with a heating element, disconnect it from the mains first.

Clean the exterior of the tank with a soft cloth and a mild detergent. Never use abrasive cleaners or solvents. Check all connection for leaks.

The tanks are equipped with an anti-corrosion sacrifice magnesium anode rod. The anode rod shall be checked within 6 months after commissioning and subsequently always not later than 6 months after the last check. If more than 1/3 of its total volume is consumed, the anode shall be replaced with a new one. Disregarded of its state, the anode rod shall be replaced with a new one within 24 months from commissioning. In case an electronic anode is used, the above described procedures are not necessary. Then only a visual check of the indication lamp is necessary every 3 months.

Proper working of the Electronic Anode is described in its User's Manual.

If damage to a tank occurs due to neglected substitution of a magnesium anode rod or a non-working electronic anode, the warranty cannot be claimed.

8 - Disposal

Packing shall be disposed of in compliance with the valid rules. When the product reaches the end of its life, it shall not be disposed of as household waste. It shall be dropped off at a Local Waste Recycling Center. Insulation shall be recycled as plastic and the steel vessel as scrap iron.

9 - Warranty

This product is covered by warranty according to the conditions described in this Manual and according to the Warranty Certificate. A Warranty Certificate is an integral part of the supply. Tank transport or storing in a horizontal position is considered a warranty violation!

06/2010



REGULUS spol. s r.o.
Do Koutů 1897/3
143 00 Praha 4

<http://www.regulus.eu>
E-mail: sales@regulus.cz